

BRIEF COMMUNICATION

# Analysis of Head Movement and Position Using Hall Effect Devices

R. NIENHUIS AND J. M. SIEGEL<sup>1</sup>

Neurobiology Research (151 A3), Sepulveda VAMC, Sepulveda, CA 91343 Department of Psychiatry, UCLA School of Medicine, 760 Westwood Plaza, Los Angeles, CA 90024

Received 18 July 1988

NIENHUIS, R. AND J. M. SIEGEL. *Analysis of head movement and position using Hall effect devices.* PHYSIOL BEHAV 45(1) 199-203, 1989.—We describe a system for the analysis of head displacement and angle. This system utilizes an inexpensive array of Hall effect transducers and associated electronics. Computer analysis of the output of the system permits real time display of head angle, position and associated velocity measures.

Head movement      Movement      Hall effect

THE "Hall Effect" is the generation of a voltage across opposite edges of an electrical conductor carrying current. It is produced when the conductor is placed in a magnetic field (7). Inexpensive semiconductor based devices which develop voltages several orders of magnitude higher than those previously seen in metals have recently become available. The present paper describes a system using Hall effect transducers to detect both head angle and displacement. Similar systems could be used for quantification of other movements.

## METHOD

The Hall effect movement detector system consists of four subsystems: the magnet, the sensors, the amplifiers, and the computer and related software system. The components are listed in Table 1 and the schematic is presented in Fig. 1.

### Magnet

A powerful cobalt magnet (8500 gauss) weighing 100 grams (Edmund Scientific) or a neodymium magnet (PerMag Corp.) weighing 60 grams was used. The magnet was affixed to the animal's headplug and provided the magnetic field used by the system to measure head rotation. The magnet was positioned so that, with the cat's head straight forward, the North-South axis formed a 0° angle with the plane in which the sensors were mounted. This provides maximum resolution for head movements in the normal range. Resolution would be minimal at a 90° orientation.

### Sensors

F. W. Bell type FH540 Hall effect sensors were used. These are inexpensive (approximately \$12 each) and reasonably sensitive and stable. The Hall devices were mounted on ferrite rods. The ferrite rods increase the density of magnetic flux lines through the Hall device by decreasing the reluctance of the flux path. The devices were attached with Epoxy.

Antenna coil cores, which are made of ferrite, were used as flux collectors. The rods measured five cm long, one cm wide and 6 mm thick. Each Hall device was mounted between a pair of the ferrite rods leaving a flux gap of approximately 0.25 mm. The devices were glued between the overlapping ends of the 1 cm wide sides of the flux collectors, so that the entire assembly was 9 cm long. The flux collectors extended in opposite directions from their point of attachment to the Hall transducer (Fig. 1—bottom).

The sensors were affixed to a square, wooden frame measuring 30 cm on each side. Four sensors were attached, one at the midpoint of each side of the frame, so that when the animal was placed with its head in the center of the frame, left and right, as well as up and down information could be derived.

### Amplifiers

Precision Monolithics type OP02 D-C operational amplifiers were used because of their low drift and low noise characteristics. All resistors were .1% metal film type, also used because of their low noise and drift characteristics. A ten

<sup>1</sup>Requests for reprints should be addressed to J. M. Siegel, Neurobiology Research (151A3), UCLA Department of Psychiatry, Sepulveda VAMC, Sepulveda, CA 91343.

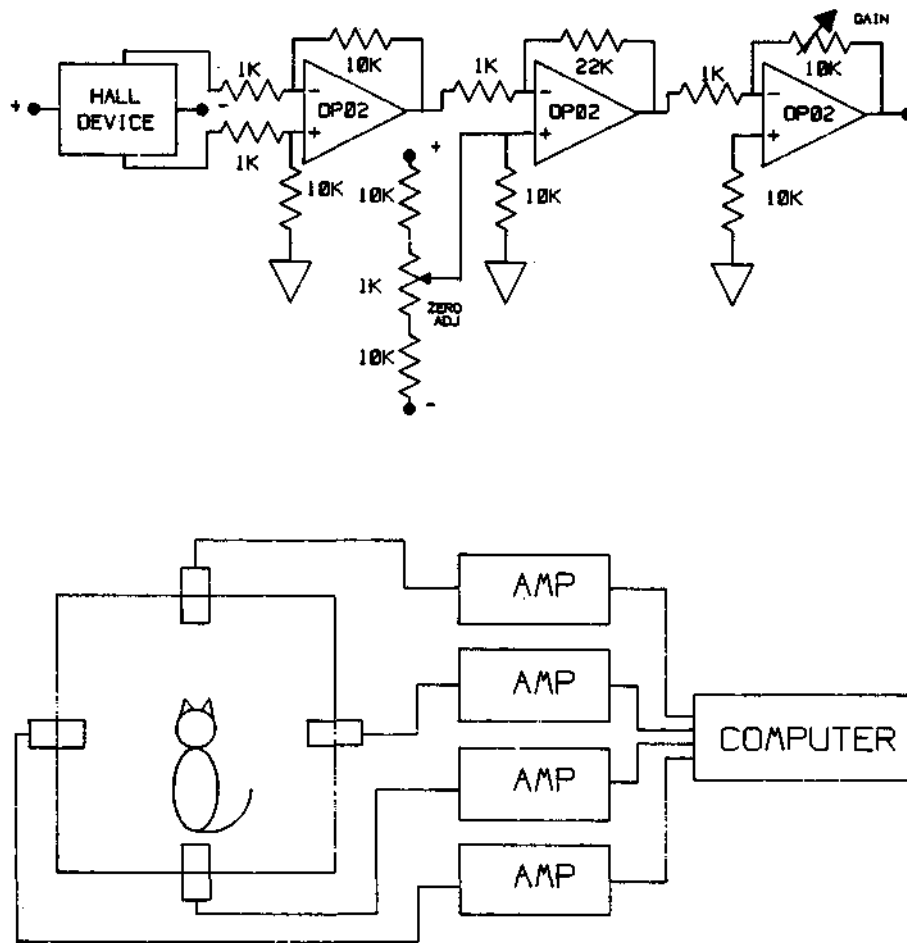

FIG. 1. Top: Schematic for Hall device amplifier. Bottom: Illustration of spatial array of sensors with flux collectors and connection through the amplifier (AMP) to the computer.

turn, 1 kohm potentiometer was employed for zero adjustment, and another 10 kohm potentiometer was provided for gain adjustments. See Fig. 1 for details. A 15 mA constant current source provided excitation current for the Hall transducers.

#### Computer

A DEC MINC PDP 11/23 computer system was used to collect the analog input from the sensor amplifiers. The data were digitized, scaled, filtered and corrected for off center position. The processed and filtered digital data were then scaled and converted back to analog values proportional to the amount of rotation in degrees on one channel and the angular velocity of movement (the derivative of the rotation) on another channel. Displacement data could be simultaneously provided on a third channel. Figure 2 presents a real time polygraphic display of EEG, EOG and muscle activity data, along with head position and velocity measures calculated "on-line" by the system.

Programing was done in FORTRAN, using the DEC MINC FORTRAN Enhancement Package to control the MINC analog to digital and digital to analog converters. The program is available from the authors.

#### System Operation

The cat's body was placed in a bag, secured to prevent rolling, positioned so that the head was between the Hall sensors. The magnet was affixed with a plug mounted in the acrylic pedestal on the animal's head and a mating plug similarly secured to the magnet. The computer converted the analog signals from the Hall sensors into digital values.

Hall sensors are sensitive to both the flux density of a magnetic field ( $\beta$ ), and the sine of the angle that the sensor makes with the orientation of that field (SINE<sup>®</sup>). Therefore, the Hall output voltage equation is expressed as:

$$V_{\text{Hall}} = \beta \text{ SINE}(i)$$

In our case, with the magnet centered in the frame holding the Hall sensors, the field intensity is constant at a fixed distance from the magnet, and therefore the Hall output voltage becomes purely a function of the sine of the angle that the sensor makes with the orientation of the field. In other words, if the centered magnet is rotated on its axis, the Hall sensor output voltage describes a sine curve. Therefore a simple arcsine transform will provide a voltage proportional to number of degrees of rotation.

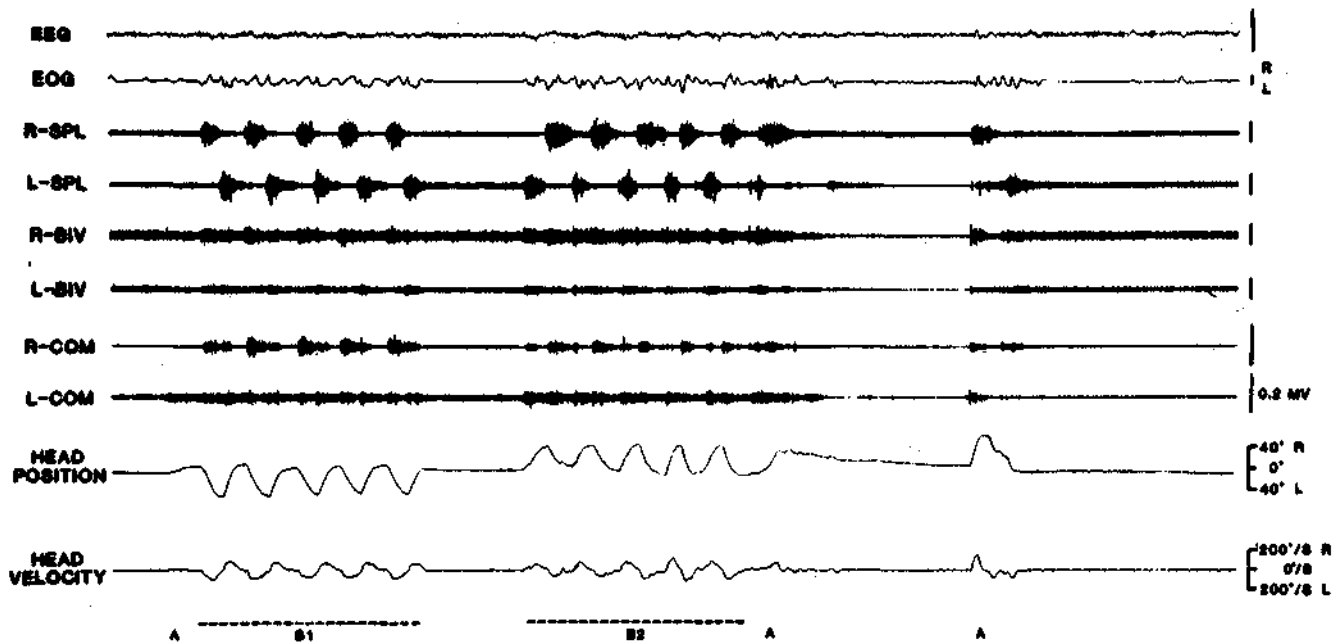

FIG. 2. Recording of head movement position and velocity during repetitive passive head movement to the left (B1) or right (B2) side and during spontaneous active (A) movements. EEG, sensorimotor electroencephalogram; EOG, A-C electrooculogram; R- L- SPL, right and left splenius muscles; BIV, biventer; COM, complexus.

TABLE 1  
HALL EFFECT SYSTEM COMPONENTS

- Operational amplifiers: No. OP02  
Precision Monolithics 1500 Space  
Park Dr. Santa Clara, CA 95050
- Hall Effect device: No. FH540  
F. W. Bell Corp. 6120 Hanging  
Garden Rd. Orlando, FL 32807
- High power cobalt magnets: No. D30, or No. 964  
Edmund Scientific  
101 E. Gloucester Pike  
Barrington, NJ 08007  
OR: Neodymium magnet, No. ND32S7031A  
PerMag Corp.  
10631 Humbolt St.  
Los Alimitos, CA 90720
- Ferrite rod flux collectors: (Surplus antenna coil cores) C  
and H Sales Co. 2176 E Colorado Bl. Pasadena, CA  
91107
- Metal film precision resistors  
Dow Radio 1759 E Colorado  
Bl. Pasadena, CA 91106

When the magnet is centered in the frame and rotated, both the left and right Hall sensors should measure equal voltages. Thus when the magnet is displaced either to the left or right, the Hall voltages will be unequal and the ratio of the absolute values of the voltages can be used as an error signal, and as a measure of the displacement of the magnet. The error signal can be used to calculate displacement, and to correct for displacement in the calculation of the angle values.

$\beta$  is a function of magnet strength (a constant  $M$ ) and the reciprocal of the distance from the magnet cubed ( $M/D^3$ ). Therefore the Hall voltage produced by the right sensor can be expressed as:

$$V_{HallR} = M \text{SINE}(\Theta)/D^3$$

If the magnet is moved  $d$  centimeters closer to the right sensor the expression becomes:

$$V_{HallR} = M \text{SINE}(\Theta)/(D-d)^3$$

and the left Hall voltage is:

$$V_{HallL} = M \text{SINE}(\Theta)/(D+d)^3$$

Since  $M$  is a constant, and the magnet makes the same angle with both Hall sensors, we can substitute and rearrange terms to produce the expression:

$$V_{HallR}/V_{HallL} = (D+d)^3/(D-d)^3$$

Since  $D$  is a constant, the ratio of the two Hall voltages is independent of rotation ( $\Theta$ ), and depends only on the distance from the center position ( $d$ ). At  $90^\circ$  ( $\text{SINE}(\Theta) = 1$ )  $V_{Hall} = \beta$ . Therefore, by holding the magnet at  $90^\circ$ , we

can construct a graph of values of  $\beta$  at various values of  $d$ . We then use that graph (for calculation purposes we converted that graph into an interpolating polynomial using Newton's method) to retrieve the  $\beta$  value at  $90^\circ$ . Then, since:

$$V_{\text{Hall}}/\beta = \text{SINE}(\Theta)$$

we can compute the actual  $\text{SINE}(0)$ . For example, if the Hall voltage sensor at distance  $d$  reads a voltage that is 0.707 times the voltage at  $90^\circ$  at that same distance, we know that the magnet is at an angle of  $45^\circ$ .

A second pair of sensors, oriented in the Y axis, was similarly processed. Together, the output of the two pairs of sensors describe both pitch and yaw movements of the head, and translations of the head in both dimensions. Combinations of displacements in the X and Y axes would produce corresponding translation signals (differences in the Hall voltages of the two sensors) in the X and Y pairs of Hall devices. A roll movement of the head about the rostral caudal axis of the animal would produce no translational signal in either pair of detectors and would produce equal angle indications (altered but equal voltages in both Hall devices) in both pairs. We have also utilized a third pair of sensors, oriented in the Z axis to perform a three dimensional description of translation and rotation information, although we have not found this to be necessary for describing the normal range of head movements in a cat positioned as described above.

The program performs a low pass digital filtering of the data, does an arcsine transformation to determine rotation in degrees, and computes angular velocity. The rotation, angular velocity, and displacement measures are converted back to analog values for output to an oscilloscope or polygraph.

#### *Sources of Error*

The system operates by comparing measured voltages against the mathematical model. The model was constructed by measuring the system output voltages at a set of points at various distances from the magnet, and then creating a continuous function from those points by the use of Newton's interpolating polynomial. This approach was used for several reasons. First, the ferrite rods used as flux collectors tend to saturate at higher flux densities, causing the Hall voltage/distance curve to flatten out when the magnet is close to the transducer. Our approach readily compensated for such system nonlinearities, since an interpolating polynomial can be fitted to any arbitrary function. Second, magnets change their properties as they age, get damaged, etc. Our approach allowed a convenient method of recalibrating the system as magnetic properties changed or different magnets were used. And third, the use of a continuous function rather than a set of discrete steps, as from a table for example, provides much better resolution.

Because of the saturation of the ferrite rods and transducers, the actual voltage produced as the magnet approaches the transducer differs strongly from an inverse cube function. At 5 cm displacement of the magnet produces, as expected, a  $V_{\text{Hall}}/V_{\text{Hall}}$  voltage ratio of about 8. A 10 cm displacement produces a ratio of about 40, instead of the expected ratio of 125. This curve flattening extends the range of the system, in effect, providing some data compression at the extremes of excursion. Thus, with the particular transducer/flux collector combination we used, the system could

operate over a displacement range of  $\pm 10$  cm before the limits of the A/D converters were reached. But, because the model is constructed from the measured system response instead of the theoretical curve, the nonlinearity of the curve does not limit the ability of the system to accurately measure angles.

The accuracy of the model depends on the number of points used. Using sixteen points to construct the model, we observed less than a one percent error at the center of the system, and less than two percent error with a lateral deviation of ten cm. Accuracy could be increased by using more points to construct the model, at a cost of decreased sampling rate, which in our system was 1000 Hz.

The accuracy of the system also depends on real time measurement errors. The primary cause of this error is drift in the power supply and amplifiers. Over short periods it is possible to achieve a maximum error of 2.5 degrees (2,7%) at a deviation from center of 6 cm. Because the system uses ratios of voltages, the effects of drift are greatest at the furthest lateral excursion of the magnet. When the magnet is centered, a 10 mV drift produces about 5 degrees of error. At six cm of lateral displacement, the same 10 mV drift produces an error of 11 degrees. This source of error can be minimized by the use of low drift power supplies, chopper stabilized amplifiers, continuous operation, proper ventilation and regular (daily) calibration. To confirm that accuracy was maintained in actual use we performed frame by frame video analysis of a simultaneous recording of the animals' head movement and an X-Y oscilloscopic display of calculated head position. These measures corresponded to within the resolution limits of the video system.

#### *Resolution*

The MINC system uses a 12 bit A/D converter. With a maximum input of 10 volts the resolution is about 2.5 mV per bit. In our system, this translates to an ultimate resolution of about 0.2 degrees.

#### DISCUSSION

This system has two advantages over the search coil technique, which is in widespread use for the measurement of eye and head movement (1, 3, 4, 6). The first is its ability to calculate displacement as well as angle information. The second advantage is its low cost. The total cost of the electronics for a two channel system should be approximately \$150 with an additional cost of \$100 for the magnet. Simple systems utilizing a single Hall effect device have been successfully used in the analysis of jaw displacement (2,5).

One limitation of the present technique is the need to mount a strong magnet on the body part in motion. The inertia produced by a 60 g magnet somewhat reduces the acceleration of the cat's head, which weighs approximately 300 grams. In an actual recording situation, the cable attached to the head produces an additional inertia in the range of 200-300 grams. Thus, while the contribution of the magnet is significant, it is relatively small compared to these other factors. In smaller animals, it would be possible to use less powerful, lighter magnets, while monitoring a more restricted range of displacements. With the development of magnets with higher levels of gauss per gram of weight, the weight of the magnet will become less of a consideration. Further extension might be possible by combining the procedures described here with the search coil technique. The Hall sensors respond to the low frequency or D-C end of the

spectrum, while high frequency signals are used in search coil techniques for recording eye movements. With appropriate filtering, therefore, position information derived from Hall effect sensors could be combined with simultaneously derived search coil angle information.

#### ACKNOWLEDGEMENT

Supported by the Medical Research Service of the Veterans Administration and USPHS grants NS14610 and MH43811.

#### REFERENCES

1. Collewijn, H. Eye and head movements in freely moving rabbits. *J. Physiol.* 266:471-498; 1977.
2. Deich, J. D.; Houben, D.; Allan, R. W.; Zeigler, H. P. "On line" monitoring of jaw movements in the pigeon. *Physiol. Behav.* 35:307-311; 1985.
3. Guitton, D.; Douglas, R. M.; Voile, M. Eye-head coordination in cats. *J. Neurophysiol.* 52:1030-1050; 1984.
4. McElligott, J. G.; Loughnane, M. H.; Mays, L. E. The use of synchronous demodulation for the measurement of eye movements by means of an ocular magnetic search coil. *IEEE Trans. Biomed. Electron. BME* 26:370-376; 1979.
5. Nakamura, U.; Enomoto, S.; Kato, M. The role of medial bulbar reticular neurons in the orbital cortically induced masticatory rhythm in cats. *Brain Res.* 202:207-212; 1980.
6. Robinson, D. A. A method of measuring eye movement using a scleral search coil in a magnetic field. *IEEE Trans. Biomed. Electron. BME* 10:137-145; 1963.
7. The Hall effect comes into its own. *Electronic Products Magazine.* September 18. Garden City, NY; 1972:59-62 (no author).